

**CITY OF DIAMOND BAR
TRAFFIC AND TRANSPORTATION COMMISSION
AGENDA**

Thursday, May 08, 2025

**Diamond Bar City Hall
First Floor
Windmill Community Room
21810 Copley Drive, Diamond Bar**

CALL TO ORDER: 6:30 P.M.

PLEDGE OF ALLEGIANCE: Commissioner Busteded

ROLL CALL: Commissioners Busteded, Mao, Plunkett, Vice-Chair Morales, Chair Mercado

I. APPROVAL OF MINUTES:

A. T&T Commission Meeting Minutes of March 13, 2025

Recommended Action: Receive and File

II. PUBLIC COMMENTS:

This is the time and place for the general public to address the Commission. Items to be discussed here are those which do not already appear on this agenda.

III. ITEMS FROM STAFF:

A. Traffic Statistics for January & February 2024-2025

Recommended Action: Receive and File

B. Updates on Various Projects/Programs

Recommended Action: Receive and File

IV. NEW BUSINESS**1. “No Right Turn on Red” and “Yield to Pedestrians” Signage at Golden Springs Dr. & Golden Prados Dr.**

Recommended Action: Concur with staff’s recommendation to install "No Right Turn on Red" and "Turning Vehicles Yield to Pedestrians" signage at the intersection of Golden Springs Drive and Golden Prados Drive.

V. STATUS OF PREVIOUS ACTION ITEMS**VI. ITEMS FROM COMMISSIONERS:****VII. SCHEDULE OF FUTURE CITY EVENTS:**

A.	PLANNING COMMISSION MEETING – Tuesday, May 13, 2025 – 6:30 p.m., Diamond Hall Windmill Community Room, 21810 Copley Drive
B.	CITY COUNCIL MEETING – Tuesday, May 20, 2025 – 6:30 p.m., AQMD/ Government Auditorium, 21865 Copley Drive
C.	PARKS AND RECREATION COMMISSION MEETING – Thursday, May 22, 2025 – 6:30 p.m. – Diamond Bar City Hall Windmill Community Room, 21810 Copley Drive
D.	MEMORIAL DAY HOLIDAY – Monday, May 26, 2025 - City offices will be closed in observance of the holiday. We will re-open Tuesday, May 28, 2025 at 7:30 a.m.
E.	PLANNING COMMISSION MEETING – Tuesday, May 27, 2025 – 6:30 p.m., Diamond Hall Windmill Community Room, 21810 Copley Drive
F.	CITY COUNCIL MEETING – Tuesday, June 3, 2025 – 6:30 p.m., AQMD/ Government Auditorium, 21865 Copley Drive
G.	PLANNING COMMISSION MEETING – Tuesday, June 10, 2025 – 6:30 p.m., Diamond Hall Windmill Community Room, 21810 Copley Drive
H.	CITY COUNCIL MEETING – Tuesday, June 17, 2025 – 6:30 p.m., AQMD/ Government Auditorium, 21865 Copley Drive
I.	PLANNING COMMISSION MEETING – Tuesday, June 24, 2025 – 6:30 p.m., Diamond Hall Windmill Community Room, 21810 Copley Drive
J.	CITY COUNCIL MEETING – Tuesday, July 1, 2025 – 6:30 p.m., AQMD/Government Auditorium, 21865 Copley Drive

K.	4 TH OF JULY HOLIDAY – Friday, July 4, 2025 – City offices will be closed in observance holiday. We will re-open Monday, July 7, 2025 at 7:30 a.m.
L.	TRAFFIC & TRANSPORTATION COMMISSION MEETING – Thursday, July 10, 2025 p.m., Diamond Bar City Hall Windmill Community Room, 21810 Copley Drive

VIII. ADJOURNMENT

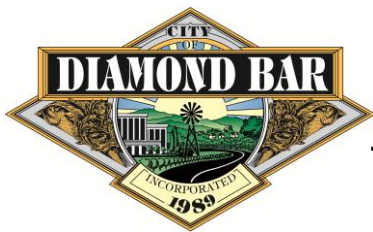

TRAFFIC & TRANSPORTATION COMMISSION AGENDA REPORT

CITY OF DIAMOND BAR ~ 21810 COPLEY DRIVE ~ DIAMOND BAR, CA 91765 ~ TEL. (909) 839-7040 ~ FAX (909) 861-3117

AGENDA ITEM NUMBER: **1.A**

MEETING DATE: May 8, 2025

TO: Chair and Members of the Traffic and Transportation Commission

FROM: David G. Liu, Public Works Director/City Engineer

SUBJECT: T&T Commission Meeting Minutes of March 13, 2025

RECOMMENDATION: Receive and File

Attached for your review and approval are the T&T Commission Meeting Minutes of March 13, 2025.

Attachments:

1. T&T Commission Meeting Minutes - 3-13-25

**CITY OF DIAMOND BAR
MINUTES OF THE TRAFFIC & TRANSPORTATION COMMISSION
DIAMOND BAR CITY HALL WINDMILL ROOM
21810 COPLEY DRIVE, DIAMOND BAR, CA 91765
MARCH 13, 2025**

CALL TO ORDER:

Chair Morales called the meeting to order at 6:30 p.m.

PLEDGE OF ALLEGIANCE: Chair Morales led the Pledge of Allegiance

ROLL CALL: Commissioners Gary Busted, Amy Mao, Patrick Mercado, Vice-Chair Raphael Plunkett, Chair Romulo Morales

ABSENT: None

Staff present: David Liu, Public Works Director; Hal Ghafari, Public Works Manager/Assistant City Engineer; Christian Malpica, Associate Engineer (Traffic); Vivian Chen, Associate Engineer; Nicholas Delgado, Public Works Management Analyst; Marcy Hilario, Administrative Coordinator

I. INTRODUCTION OF NEW COMMISSIONERS

II. REORGANIZATION OF THE TRAFFIC & TRANSPORTATION COMMISSION

Chair Morales nominated Commissioner Mercado to serve as Chair. C/Busted seconded. Motion carried by the following Roll Call vote:

AYES: COMMISSIONERS: C/Busted, C/Mao, C/Mercado, C/Morales, C/Plunkett

ABSENT: COMMISSIONERS: None

ABSTAIN: COMMISSIONERS: None

C/Busted nominated Commissioner Morales to serve as Vice-Chair. C/Plunkett seconded. Motion carried by the following Roll Call vote:

Attachment: T&T Commission Meeting Minutes - 3-13-25 (T&T Commission Meeting Minutes of March 13, 2025)

AYES: COMMISSIONERS: Busteed, Mao, Morales, Plunkett, Chair/
Mercado

ABSENT: COMMISSIONERS: None

ABSTAIN: COMMISSIONERS: None

III. APPROVAL OF MINUTES:

- A. Traffic and Transportation Commission Special Meeting Minutes of December 12, 2024

C/Plunkett moved, C/Busteed seconded, to approve the Special Meeting Minutes of December 12, 2024. Motion carried by the following Roll Call vote:

AYES: COMMISSIONERS: Busteed, Plunkett, VC/Morales

ABSENT: COMMISSIONERS: None

ABSTAIN: COMMISSIONERS: C/Mao, Chair/Mercado

- IV. **PUBLIC COMMENTS:** Michael Kight, 23204 Antler Drive, Diamond Bar, CA 91765. Requested a “No Right Turn on Red” sign at the intersection of Golden Springs Dr. and Golden Prados Dr. Staff will look into the matter.

V. ITEMS FROM STAFF:

- A. **TRAFFIC STATISTICS – NOVEMBER & DECEMBER 2023/2024**

C/Busteed moved, C/Plunkett seconded, to receive and file the November & December 2023/2024 Traffic Statistics Report. Motion carried by the following Roll Call vote:

AYES: COMMISSIONERS: Busteed, Mao, Plunkett, VC/
Morales, Chair/Mercado

ABSENT: COMMISSIONERS: None

ABSTAIN: COMMISSIONERS: None

B. MONTHLY UPDATES OF VARIOUS PROJECTS/PROGRAMS:

C/Plunkett moved and C/Busteed seconded to approve the Monthly Updates of Various Projects/Programs. Motion carried by the following Roll Call vote:

AYES: COMMISSIONERS: Busteed, Mao, Plunkett, VC/
Morales, Chair/Mercado

ABSENT: COMMISSIONERS: None

NOES: COMMISSIONERS: None

VI. STATUS OF PREVIOUS ACTION ITEMS: None

VII. ITEMS FROM COMMISSIONERS:

C/Plunkett asked about new bike lanes information regarding e-bikes and scooters. Questions were answered by PWD/Liu.

VIII. SCHEDULE OF FUTURE CITY EVENTS:

As presented in the Agenda.

IX. ADJOURNMENT: There being no further business to come before the Traffic and Transportation Commission, Chair/Morales adjourned the meeting at 7:19 p.m. to Thursday, May 8, 2025 at 6:30 p.m.

The foregoing minutes are hereby approved this _____ day of _____, 2025.

Respectfully Submitted,

David G. Liu, Secretary

Attest:

Chair Patrick Mercado

Attachment: T&T Commission Meeting Minutes - 3-13-25 (T&T Commission Meeting Minutes of March 13, 2025)

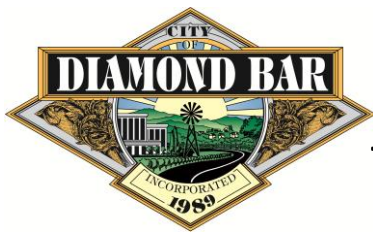

TRAFFIC & TRANSPORTATION COMMISSION AGENDA REPORT

CITY OF DIAMOND BAR ~ 21810 COPLEY DRIVE ~ DIAMOND BAR, CA 91765 ~ TEL. (909) 839-7040 ~ FAX (909) 861-3117

AGENDA ITEM NUMBER: **3.A**

MEETING DATE: May 8, 2025

TO: Chair and Members of the Traffic and Transportation Commission

FROM: David G. Liu, Public Works Director/City Engineer

SUBJECT: Traffic Statistics for January & February 2024-2025

RECOMMENDATION: Receive and File

Attached for your review are the Traffic Statistics Reports for the months of January and February – 2024-2025 as submitted by the L.A. County Sheriff's Department. Both years have been provided for side-by-side comparison.

Attachments:

1. Traffic Statistics - Jan & Feb 2024-25

COLLISIONS



JANUARY

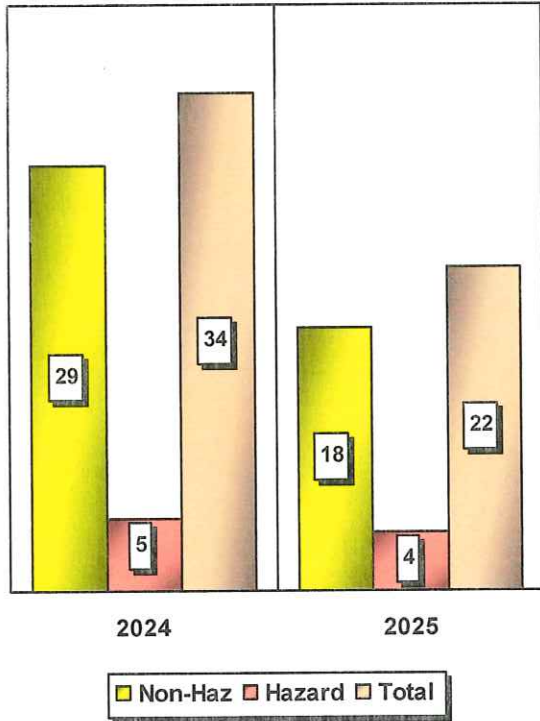

January 2024 DUI Arrests – 0 / DUI Collisions – 0
 November 2024 DUI Arrests – 0 / DUI Collisions – 0

FEBRUARY

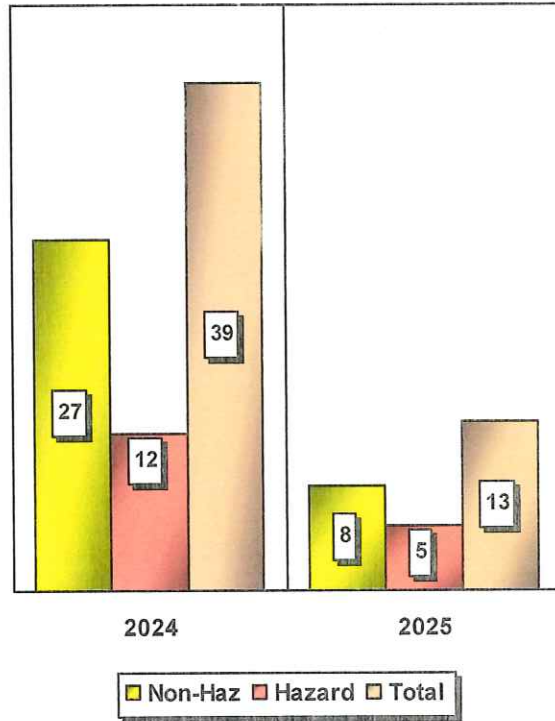

February 2024 DUI Arrests – 2 / DUI Collisions – 0
 February 2025 DUI Arrests – 1 / DUI Collisions – 0

CITATIONS



JANUARY

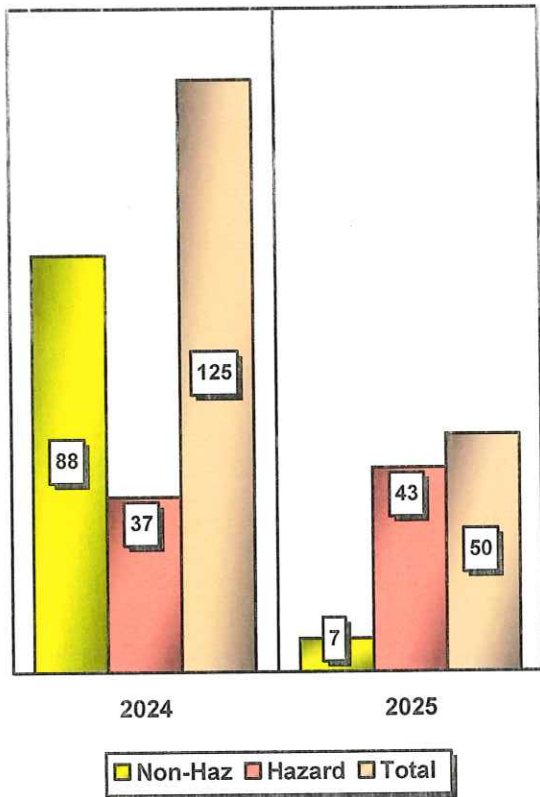

FEBRUARY

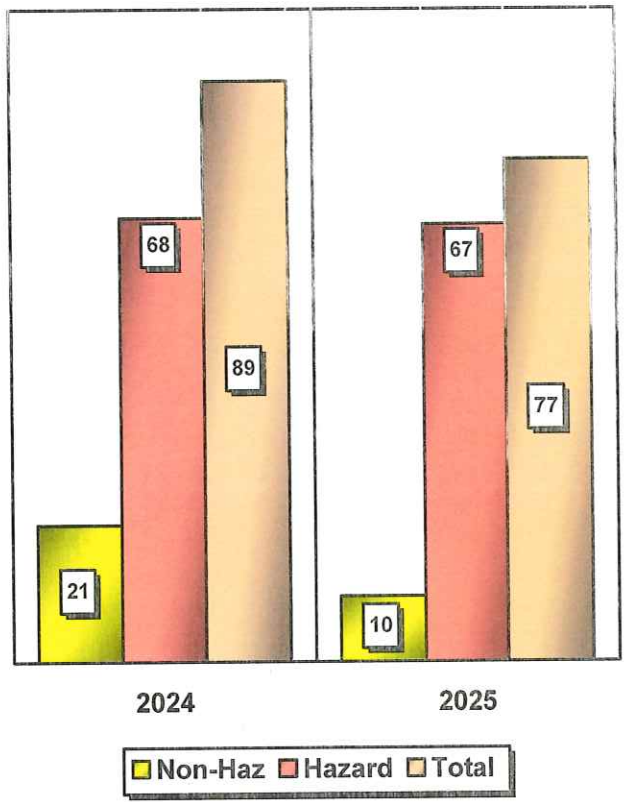

Attachment: Traffic Statistics - Jan & Feb 2024-25 (Traffic Statistics for January & February 2024-2025)

STREET SWEEPING



JANUARY

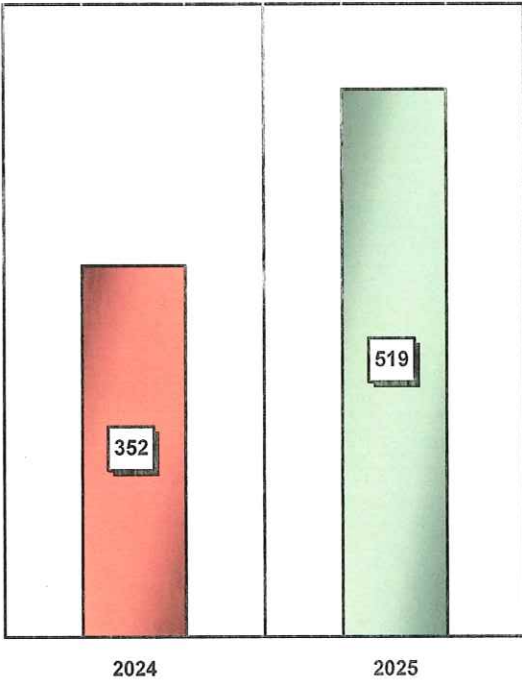

FEBRUARY

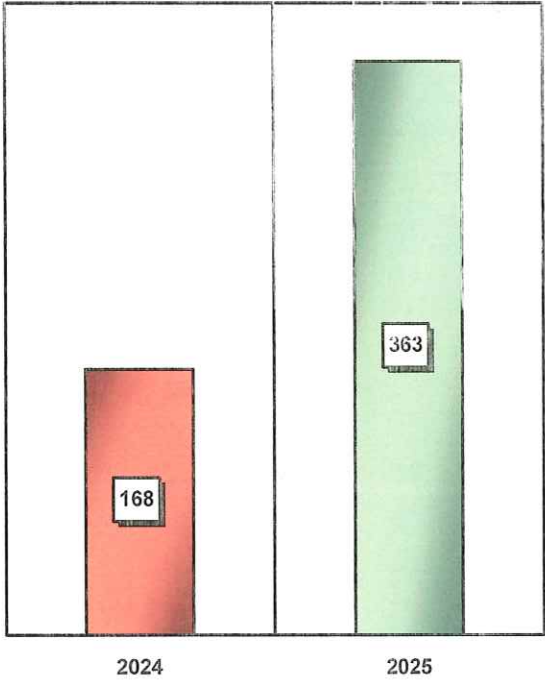

Attachment: Traffic Statistics - Jan & Feb 2024-25 (Traffic Statistics for January & February 2024-2025)

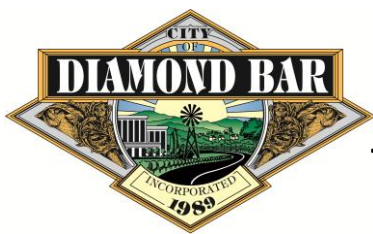

TRAFFIC & TRANSPORTATION COMMISSION AGENDA REPORT

CITY OF DIAMOND BAR ~ 21810 COPLEY DRIVE ~ DIAMOND BAR, CA 91765 ~ TEL. (909) 839-7040 ~ FAX (909) 861-3117

AGENDA ITEM NUMBER: **3.B**

MEETING DATE: May 8, 2025

TO: Chair and Members of the Traffic and Transportation Commission

FROM: David G. Liu, Public Works Director/City Engineer

SUBJECT: Updates on Various Projects/Programs

RECOMMENDATION: Receive and File

A. Grand Avenue and Golden Springs Drive Intersection Improvements

Public Works continues to collaborate closely with the City of Industry, along with its project manager and inspectors, to ensure the successful completion of the Project. The majority of punch-list items have been successfully addressed, and SCE is now close to completing the final repairs needed to energize the streetlight poles. Once this work is completed, the city will be able to formally close out the Project.

B. Highway Safety Improvement Program Grant Project

The project has been successfully completed, with all final tasks and quality checks finalized. The Notice of Completion was officially filed with the City Council at the May 20th meeting, marking the formal conclusion of the project. The following intersections were upgraded as part of this effort: Diamond Bar Blvd & Sunset Crossing Rd, Diamond Bar Blvd & Golden Springs Dr, Diamond Bar Blvd & Pathfinder Rd, Diamond Bar Blvd & Brea Canyon Rd, Golden Springs Dr & Carpio Dr, Brea Canyon Rd & Golden Springs Dr, Grand Ave & Diamond Bar Blvd, and Pathfinder Rd & Fern Hollow Dr / Brea Canyon Rd.

The final construction cost totaled \$270,981.77, which is \$30,644.23 under the

authorized amount of \$301,626.00 (construction agreement: \$251,355.00; contingency: \$50,271.00).

C. SR-57/60 Confluence Improvements Project

A 59-hour closure was scheduled on Grand Avenue as part of the State Route 57/60 Confluence Project. This closure affected the southbound lanes on the Grand Avenue Bridge and the eastbound SR-60 Grand Avenue off-ramp. The closure began the night of Friday, May 2, 2025, and continued through the morning of Monday, May 5, 2025. Planned work included utility relocations, roadway excavation, paving, and striping.

Meanwhile, construction continues on the Golden Springs Drive undercrossing, including work on the bridge stem and soffit, retaining wall foundations and footings along eastbound SR-60, storm drain relocations at various locations, roadway improvements on Grand Avenue, and utility relocations along Grand Avenue. These activities require intermittent daytime closures and full nighttime detours.

To keep the community informed, City staff, in coordination with the Community Relations team, continues to provide timely updates regarding these closures.

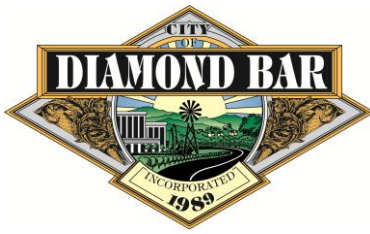

TRAFFIC & TRANSPORTATION COMMISSION AGENDA REPORT

CITY OF DIAMOND BAR ~ 21810 COPLEY DRIVE ~ DIAMOND BAR, CA 91765 ~ TEL. (909) 839-7040 ~ FAX (909) 861-3117

AGENDA ITEM NUMBER: **4.1**

MEETING DATE: May 8, 2025

TO: Chair and Members of the Traffic and Transportation Commission

FROM: David G. Liu, Public Works Director/City Engineer

SUBJECT: "No Right Turn on Red" and "Yield to Pedestrians" Signage at Golden Springs Dr. & Golden Prados Dr.

RECOMMENDATION: Staff recommends that the Traffic and Transportation Commission concur with the installation of "No Right Turn on Red" and "Turning Vehicles Yield to Pedestrians" signage at the intersection of Golden Springs Drive and Golden Prados Drive, and receive and file this memorandum along with the attached supporting technical memo.

BACKGROUND/DISCUSSION:

In response to ongoing vehicle-pedestrian conflicts at the intersection of Golden Springs Drive and Golden Prados Drive, staff proposes the installation of targeted traffic control signage to enhance pedestrian safety and address restricted sight distance issues for turning vehicles.

A recent field evaluation by the City's traffic consultant identified several concerns, including limited sight distance for eastbound right-turning vehicles from Golden Prados Drive, obstructed by residential walls along Golden Springs Drive. Drivers were frequently observed encroaching into the crosswalk to improve visibility, increasing the potential for conflicts with pedestrians. Although overall pedestrian volumes were low, consistent pedestrian activity was observed due to nearby transit stops and city park. Additionally, conflicts were reported by the public involving westbound vehicles failing to

yield to pedestrians crossing Golden Springs Drive.

While the consultant recommended installing "Turning Vehicles Yield to Pedestrians" signage, City staff determined that the combination of restricted visibility, operational risks, engineering judgment, limited community access points, and pedestrian exposure warrants a more proactive safety approach. Staff recommends with the concurrence of the consultant to installing a "No Right Turn on Red" sign on the signal pole located at the southeast corner of the intersection to control eastbound right-turning vehicles exiting Golden Prados Drive. A "Yield to Pedestrians" sign is also proposed for installation at the northwest corner to address westbound turning movements.

The "No Right Turn on Red" signage is intended to minimize pedestrian exposure in the crosswalk and reduce conflicts with high-speed southbound through traffic, so eliminating rolling right turns and improving overall intersection safety. Similarly, the "Yield to Pedestrians" signage will reinforce the need for turning vehicles to yield to pedestrians within the crosswalks.

This combined strategy is intended to enhance pedestrian protection, address visibility limitations for turning vehicles, and improve overall compliance with right-of-way rules at the intersection. While consistent with the consultant's findings, the staff's recommendation reflects a more proactive and comprehensive approach based on engineering judgment and observed field conditions.

RECOMMENDATION:

Staff recommends that the Traffic and Transportation Commission concur with the installation of "No Right Turn on Red" and "Turning Vehicles Yield to Pedestrians" signage at the intersection of Golden Springs Drive and Golden Prados Drive, and receive and file this memorandum along with the attached supporting technical memo.

Attachments:

1. Vicinity Map - Regulatory Signs
2. Attachment - Signage Assessment for Golden Springs-Golden Prados Memo

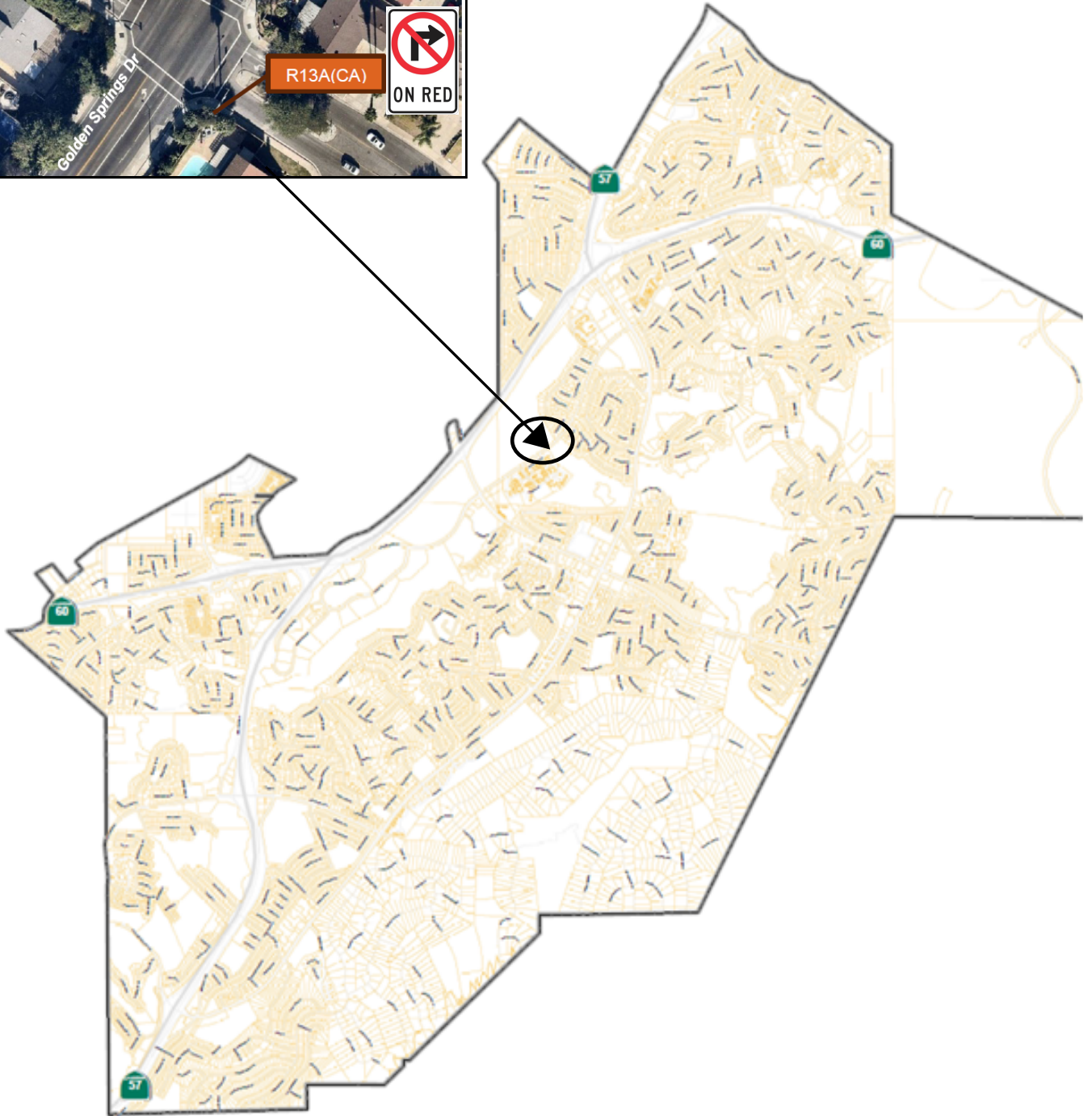

Attachment: Vicinity Map - Regulatory Signs ("No Right Turn on Red" and "Yield to Pedestrians" Signage at Golden Springs Drive & Golden



Vicinity Map

Regulatory Signs at Golden Springs Drive & Golden Prados Drive

TECHNICAL MEMORANDUM

To: Christian Malpica, Associate Engineer, City of Diamond Bar

From: Sowmya Chandrasekhar, P.E., T.E., PTOE
Ruben Becerra, P.E.

Date: April 28, 2025

Subject: Signage Assessment at Golden Springs Drive & Golden Prados Drive Intersection

1.0 INTRODUCTION

Kimley-Horn and Associates, Inc. (“Kimley-Horn”) has been retained by the City of Diamond Bar (“City”) to prepare a signage assessment at the intersection of Golden Springs Drive and Golden Prados Drive (“study intersection”). The City intends to evaluate addition of signage at the study intersection based on community input, specifically pedestrian safety concern for vehicles making eastbound or westbound turns from Golden Springs Drive. Driver compliance of right-turning vehicles yielding to pedestrian was documented for each minor street approach. The analysis is based on the criteria listed in the California Manual on Uniform Traffic Control Devices (CA MUTCD), Section 2B.4, and California Department of Transportation (Caltrans) Highway Design Manual (HDM) guidelines, Chapters 200 and 400. The aerial view of the study intersection is shown in **Exhibit 1**.



Exhibit 1 – Study Intersection: Golden Springs Drive and Golden Prados Drive

2.0 EXISTING CONDITIONS

The study intersection is a four-legged signalized intersection, with Golden Springs Drive running primarily in the north-south direction and Golden Prados Drive running primarily in the east-west direction in the vicinity of the study intersection. The posted speed limit within the study area is 45 miles per hour on Golden Springs Drive and 25 miles per hour on Golden Prados Drive.

The study intersection is located on a horizontal curve along Golden Springs Drive. During the field visits, it was observed that the Golden Prados Drive approach line of sight of vehicles approaching on Golden Springs Drive approaches is limited by residential walls at all four corners of the intersection. **Exhibits 2 and 3** illustrate the eastbound and westbound Golden Prados Drive right-turning vehicles creeping beyond the limit line, encroaching the marked crosswalks, in order to gain a better line of sight of vehicles approaching on Golden Springs Drive. The sight lines for westbound Golden Prados Drive are further blocked by the bus shelter along northbound Golden Springs Drive.

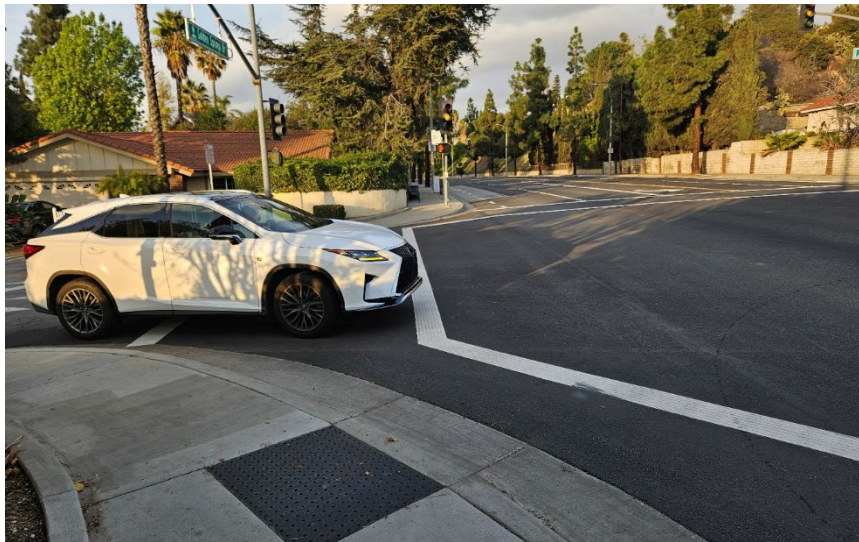

Exhibit 2 – Limited Sight Distance of Southbound Golden Springs Dr for Eastbound Golden Prados Dr Vehicles



Exhibit 3 – Limited Sight Distance of Northbound Golden Springs Dr for Westbound Golden Prados Dr Vehicles

Turning movement counts (TMCs), including vehicles, pedestrian, and bicycle volumes, were collected on Thursday, January 30, 2025, for 2-hour morning (7 to 9 AM) and evening (4 to 6 PM) peak periods. The peak hour vehicle, pedestrian and bicycle volumes are illustrated in **Exhibit 4**. The detailed data is included in **Appendix A**.

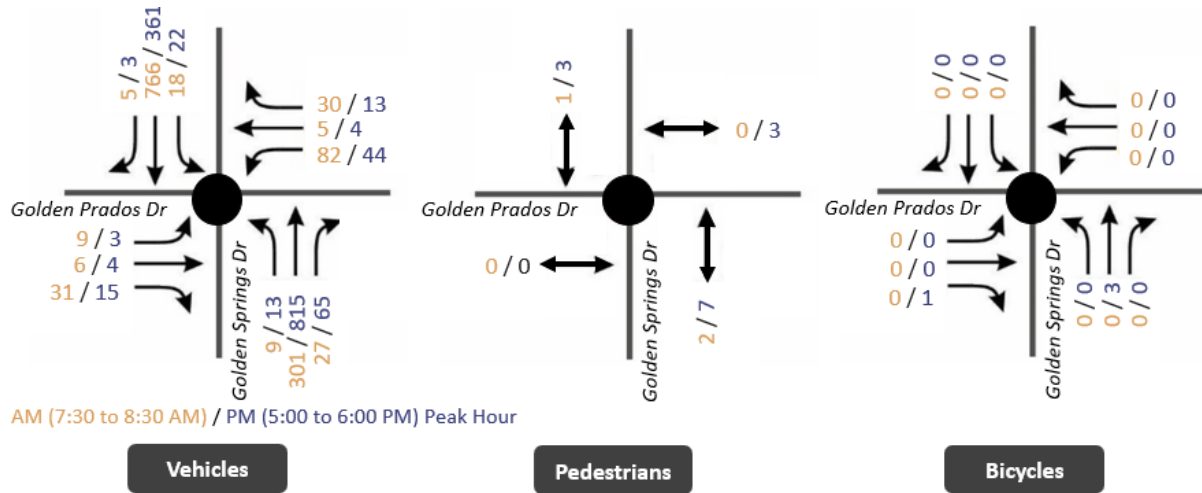

Exhibit 4 – Study Intersection Volumes

As shown in **Exhibit 4** and **Appendix A**, there were no pedestrians crossing the south leg during AM and PM peak hours, with only one pedestrian using the south leg during the entire 4-hour period that the traffic volumes were collected at the intersection. No pedestrians were observed to cross at the north leg crosswalk during the AM peak period (7 to 9 AM) and a total of five pedestrians crossed at the south leg crosswalk during the PM peak period (4 to 6 PM), with three crossing during the peak hour (5 to 6 PM). It is noted that there are two nearside bus stops along northbound and southbound Golden Springs Drive on its approaches to Golden Prados Drive. These bus stops serve Foothill Transit bus routes 482 and 853.

Kimley-Horn conducted a field visit on Tuesday, February 11, 2025, during the evening peak period (4 to 5 PM) to observe traffic operations. During this field visit, no conflict between pedestrians and vehicles was observed.

In addition, collision data from University of California Berkeley Transportation Injury Mapping System (TIMS) was obtained for a 10-year period from January 1, 2014 to December 31, 2023. Out of the three reported collisions at this intersection in a 10-year period, one involved a pedestrian and vehicle making an eastbound left-turn in the year 2016.

3.0 EVALUATION

For this study, the following references were used to analyze the existing conditions and determine the proposed treatments - Caltrans HDM Chapter 200, Topic 201 and Chapter 400, Section 405.1.2.b., and CA MUTCD, Section 2B.

CALTRANS HDM GUIDELINES

Chapter 200, Table 201.1, shown in **Exhibit 5**, provides the minimum standards for stopping sight distance related to design speed for motorists.

Design Speed ⁽¹⁾ (mph)	Stopping ⁽²⁾ (ft)	Passing (ft)
10	50	---
15	100	---
20	125	800
25	150	950
30	200	1,100
35	250	1,300
40	300	1,500
45	360	1,650
50	430	1,800
55	500	1,950
60	580	2,100
65	660	2,300
70	750	2,500
75	840	2,600
80	930	2,700

Exhibit 5 – Caltrans HDM Sight Distance Standards (Chapter 200, Table 201.1)

Chapter 400, Section 405.1.2.b states that at signalized intersections the corner sight distances should also be applied whenever possible. Even though traffic flows are designed to move at separate times, unanticipated conflicts can occur due to violation of signal, right turns on red, malfunction of the signal, or use of flashing red/yellow mode. The minimum value for corner sight distance at signalized intersections should be equal to the stopping sight distance as given in Table 201.1.

EVALUATION BASED ON HDM:

A substantially clear line of sight per HDM should be provided and maintained within the public right of way. In this case, the corner line of sight at the intersection should equal that of the stopping sight distance for the major street (Golden Springs Drive). This distance allows minor street vehicles at the limit line to ideally have enough visibility to make a safe decision and proceed through the intersections. Per table 201.1, a clear line of sight distance of 360 feet is required for vehicles on Golden Prados Drive approaches. The existing conditions (walls and bus stop shelter) for southbound and northbound restrict this distance to less than 300 feet, due to which the eastbound and westbound Golden Prados Drive right-turning vehicles pull forward into the crosswalk to gain a better line of sight.

CA MUTCD GUIDELINES

Per CA MUTCD Section 2B.54, a No Turn on Red (R10-11, R13A(CA) or R13B(CA)) sign should be considered when an engineering study finds that one or more of the following conditions exists:

- A. Inadequate sight distance to vehicles approaching from the left (or right, if applicable);
- B. Geometrics or operational characteristics of the intersection that might result in unexpected conflicts;
- C. An exclusive pedestrian phase;
- D. An unacceptable number of pedestrian conflicts with right-turn-on-red maneuvers, especially involving children, older pedestrians, or persons with disabilities;

- E. More than three right-turn-on-red accidents reported in a 12-month period for the particular approach; or
- F. The skew angle of the intersecting roadways creates difficulty for drivers to see traffic approaching from their left.

Per CA MUTCD Section 2B.53.09, in order to remind drivers who are making turns to yield to pedestrians, a Turning Vehicles Yield to Pedestrians (R10-15) sign may be used. However, it is noted that Federal Highway Administration (FHWA) interpretation of the R10-15 sign is for use at signalized intersections that might warrant additional emphasis to drivers turning at a signal where potential pedestrian conflicts might not be readily apparent.

EVALUATION BASED ON CA MUTCD:

The installation of Turning Vehicles Yield to Pedestrians (R10-15) sign may be considered to provide additional emphasis to turning drivers. However, based on CA MUTCD guidelines, Conditions A and B are met for consideration of No Turn on Red (R10-11, R13A(CA) or R13B(CA)) sign. It is noted that based on the traffic volumes collected, the right turn is the predominant movement on the eastbound/westbound Golden Prados Drive with most of the vehicles exiting the residential neighborhoods heading southbound on Golden Springs Drive. The pedestrian volume during the peak hour is significantly low (< 5 during an hour). Hence, installing a No Turn on Red sign for the eastbound approach is expected to cause some delays to vehicles making a right turn onto Golden Springs Drive.

4.0 CONCLUSIONS

Based on the field conditions, no conflicts between eastbound/westbound right-turning vehicles and pedestrians were observed. Additionally, no collisions have been reported in a 10-year period from 2014 to 2023 involving a right-turning vehicle and pedestrian. Considering the low pedestrian volumes and restricted sight distance for eastbound/westbound Golden Prados Drive, alternatives such as leading pedestrian interval are not recommended to be ideal solutions. Further, removal of south leg crosswalk was not considered due to the presence of nearside bus stops on northbound and southbound Golden Springs Drive approaches despite significantly low pedestrian volumes on the south leg.

Two conditions for the consideration of a No Turn on Red (R10-11, R13A(CA) or R13B(CA)) sign are met per CA MUTCD guidelines. Per discussion with the City, R13A(CA) sign is recommended to be installed on the far side signal pole where it will be visible for the eastbound right-turn movement, as shown in **Exhibit 6**. In addition, City recommends installing R10-15 sign on the far side signal pole facing westbound approach.



Exhibit 6 – Recommended installation locations of proposed signs

APPENDIX A: TURNING MOVEMENT COUNTS DATA

Attachment: Attachment - Signage Assessment for Golden Springs-Golden Prados Memo ("No Right Turn on Red" and "Yield to Pedestrians")

Counts Unlimited, Inc.
 PO Box 1178
 Corona, CA 92878
 (951) 268-6268

City of Diamond Bar
 N/S: Golden Springs Drive
 E/W: Golden Prados Drive
 Weather: Clear

File Name : DMB_GS_GP AM
 Site Code : 10825089
 Start Date : 1/30/2025
 Page No : 1

Groups Printed- Total Volume

Start Time	Golden Springs Drive Southbound				Golden Prados Drive Westbound				Golden Springs Drive Northbound				Golden Prados Drive Eastbound				Int. Total
	Left	Thru	Right	App. Total	Left	Thru	Right	App. Total	Left	Thru	Right	App. Total	Left	Thru	Right	App. Total	
07:00 AM	1	131	0	132	17	1	1	19	0	28	3	31	0	2	7	9	191
07:15 AM	1	183	1	185	16	1	3	20	3	44	3	50	1	0	2	3	258
07:30 AM	2	203	0	205	25	0	3	28	2	61	7	70	2	2	8	12	315
07:45 AM	6	203	0	209	24	0	19	43	2	102	9	113	2	3	10	15	380
Total	10	720	1	731	82	2	26	110	7	235	22	264	5	7	27	39	1144
08:00 AM	6	204	3	213	23	2	5	30	2	71	5	78	4	0	9	13	334
08:15 AM	4	156	2	162	10	3	3	16	3	67	6	76	1	1	4	6	260
08:30 AM	4	121	1	126	21	0	3	24	3	53	3	59	1	0	2	3	212
08:45 AM	2	154	0	156	11	0	3	14	1	66	4	71	1	2	7	10	251
Total	16	635	6	657	65	5	14	84	9	257	18	284	7	3	22	32	1057
Grand Total	26	1355	7	1388	147	7	40	194	16	492	40	548	12	10	49	71	2201
Apprch %	1.9	97.6	0.5		75.8	3.6	20.6		2.9	89.8	7.3		16.9	14.1	69		
Total %	1.2	61.6	0.3	63.1	6.7	0.3	1.8	8.8	0.7	22.4	1.8	24.9	0.5	0.5	2.2	3.2	

Start Time	Golden Springs Drive Southbound				Golden Prados Drive Westbound				Golden Springs Drive Northbound				Golden Prados Drive Eastbound				Int. Total
	Left	Thru	Right	App. Total	Left	Thru	Right	App. Total	Left	Thru	Right	App. Total	Left	Thru	Right	App. Total	
07:30 AM	2	203	0	205	25	0	3	28	2	61	7	70	2	2	8	12	315
07:45 AM	6	203	0	209	24	0	19	43	2	102	9	113	2	3	10	15	380
08:00 AM	6	204	3	213	23	2	5	30	2	71	5	78	4	0	9	13	334
08:15 AM	4	156	2	162	10	3	3	16	3	67	6	76	1	1	4	6	260
Total Volume	18	766	5	789	82	5	30	117	9	301	27	337	9	6	31	46	1289
% App. Total	2.3	97.1	0.6		70.1	4.3	25.6		2.7	89.3	8		19.6	13	67.4		
PHF	.750	.939	.417	.926	.820	.417	.395	.680	.750	.738	.750	.746	.563	.500	.775	.767	.848

Peak Hour Analysis From 07:00 AM to 08:45 AM - Peak 1 of 1
 Peak Hour for Entire Intersection Begins at 07:30 AM

Attachment: Attachment - Signage Assessment for Golden Springs-Golden Prados Memo ("No Right Turn on Red" and "Yield to Pedestrians")

Counts Unlimited, Inc.
 PO Box 1178
 Corona, CA 92878
 (951) 268-6268

City of Diamond Bar
 N/S: Golden Springs Drive
 E/W: Golden Prados Drive
 Weather: Clear

File Name : DMB_GS_GP AM
 Site Code : 10825089
 Start Date : 1/30/2025
 Page No : 2

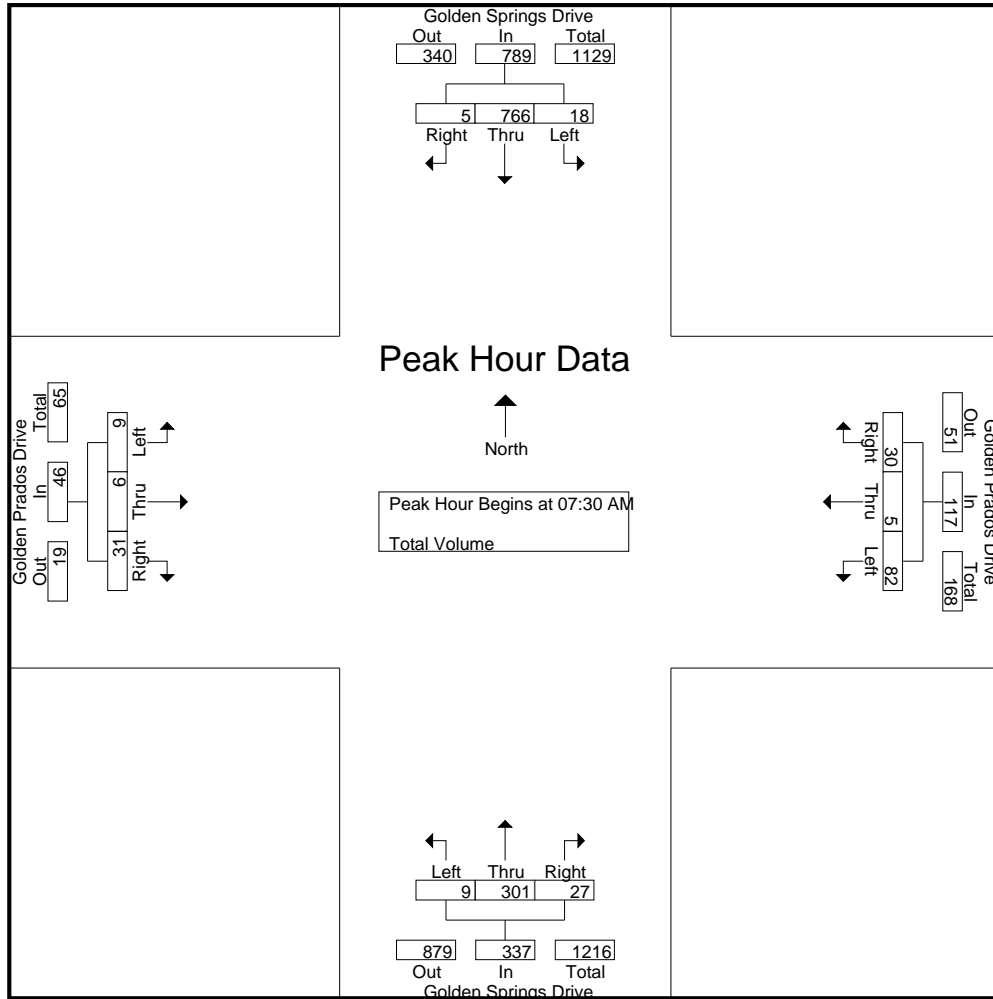

Peak Hour Analysis From 07:00 AM to 08:45 AM - Peak 1 of 1
 Peak Hour for Each Approach Begins at:

	07:15 AM				07:15 AM				07:30 AM				07:30 AM			
+0 mins.	1	183	1	185	16	1	3	20	2	61	7	70	2	2	8	12
+15 mins.	2	203	0	205	25	0	3	28	2	102	9	113	2	3	10	15
+30 mins.	6	203	0	209	24	0	19	43	2	71	5	78	4	0	9	13
+45 mins.	6	204	3	213	23	2	5	30	3	67	6	76	1	1	4	6
Total Volume	15	793	4	812	88	3	30	121	9	301	27	337	9	6	31	46
% App. Total	1.8	97.7	0.5		72.7	2.5	24.8		2.7	89.3	8		19.6	13	67.4	
PHF	.625	.972	.333	.953	.880	.375	.395	.703	.750	.738	.750	.746	.563	.500	.775	.767

Attachment: Attachment - Signage Assessment for Golden Springs-Golden Prados Memo ("No Right Turn on Red" and "Yield to Pedestrians")

Counts Unlimited, Inc.
 PO Box 1178
 Corona, CA 92878
 (951) 268-6268

City of Diamond Bar
 N/S: Golden Springs Drive
 E/W: Golden Prados Drive
 Weather: Clear

File Name : DMB_GS_GP PM
 Site Code : 10825089
 Start Date : 1/30/2025
 Page No : 1

Groups Printed- Total Volume

Start Time	Golden Springs Drive Southbound				Golden Prados Drive Westbound				Golden Springs Drive Northbound				Golden Prados Drive Eastbound				Int. Total
	Left	Thru	Right	App. Total	Left	Thru	Right	App. Total	Left	Thru	Right	App. Total	Left	Thru	Right	App. Total	
04:00 PM	3	67	1	71	6	0	3	9	2	167	12	181	4	2	3	9	270
04:15 PM	4	94	0	98	11	2	5	18	3	206	9	218	3	0	3	6	340
04:30 PM	4	112	2	118	8	1	7	16	7	177	12	196	2	0	6	8	338
04:45 PM	2	89	0	91	8	1	5	14	1	150	12	163	0	0	2	2	270
Total	13	362	3	378	33	4	20	57	13	700	45	758	9	2	14	25	1218
05:00 PM	2	87	0	89	8	1	2	11	4	211	18	233	1	1	3	5	338
05:15 PM	7	97	0	104	10	1	3	14	3	203	10	216	0	2	8	10	344
05:30 PM	6	81	1	88	13	1	3	17	3	191	20	214	1	1	0	2	321
05:45 PM	7	96	2	105	13	1	5	19	3	210	17	230	1	0	4	5	359
Total	22	361	3	386	44	4	13	61	13	815	65	893	3	4	15	22	1362
Grand Total	35	723	6	764	77	8	33	118	26	1515	110	1651	12	6	29	47	2580
Apprch %	4.6	94.6	0.8		65.3	6.8	28		1.6	91.8	6.7		25.5	12.8	61.7		
Total %	1.4	28	0.2	29.6	3	0.3	1.3	4.6	1	58.7	4.3	64	0.5	0.2	1.1	1.8	

Start Time	Golden Springs Drive Southbound				Golden Prados Drive Westbound				Golden Springs Drive Northbound				Golden Prados Drive Eastbound				Int. Total
	Left	Thru	Right	App. Total	Left	Thru	Right	App. Total	Left	Thru	Right	App. Total	Left	Thru	Right	App. Total	
05:00 PM	2	87	0	89	8	1	2	11	4	211	18	233	1	1	3	5	338
05:15 PM	7	97	0	104	10	1	3	14	3	203	10	216	0	2	8	10	344
05:30 PM	6	81	1	88	13	1	3	17	3	191	20	214	1	1	0	2	321
05:45 PM	7	96	2	105	13	1	5	19	3	210	17	230	1	0	4	5	359
Total Volume	22	361	3	386	44	4	13	61	13	815	65	893	3	4	15	22	1362
% App. Total	5.7	93.5	0.8		72.1	6.6	21.3		1.5	91.3	7.3		13.6	18.2	68.2		
PHF	.786	.930	.375	.919	.846	1.00	.650	.803	.813	.966	.813	.958	.750	.500	.469	.550	.948

Peak Hour Analysis From 04:00 PM to 05:45 PM - Peak 1 of 1
 Peak Hour for Entire Intersection Begins at 05:00 PM

Attachment: Attachment - Signage Assessment for Golden Springs-Golden Prados Memo ("No Right Turn on Red" and "Yield to Pedestrians")

Counts Unlimited, Inc.
 PO Box 1178
 Corona, CA 92878
 (951) 268-6268

City of Diamond Bar
 N/S: Golden Springs Drive
 E/W: Golden Prados Drive
 Weather: Clear

File Name : DMB_GS_GP PM
 Site Code : 10825089
 Start Date : 1/30/2025
 Page No : 2

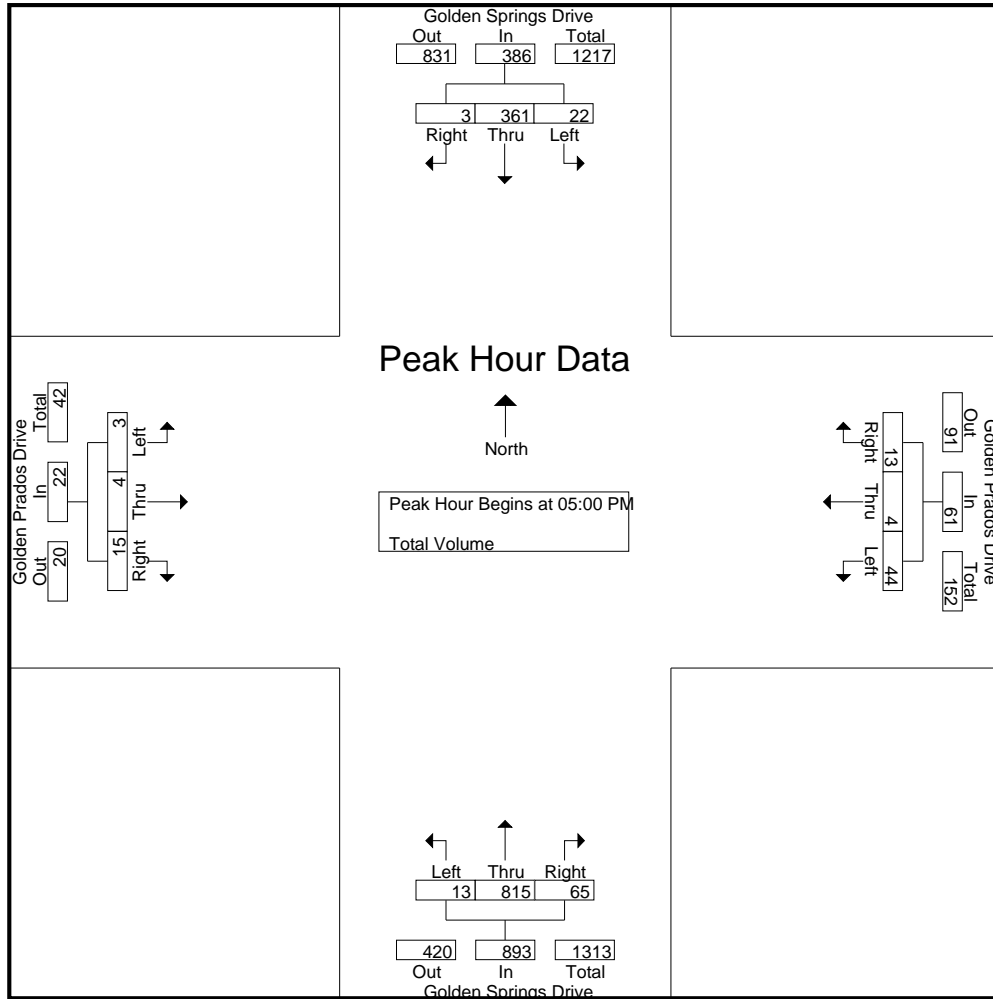

Peak Hour Analysis From 04:00 PM to 05:45 PM - Peak 1 of 1
 Peak Hour for Each Approach Begins at:

	04:30 PM				05:00 PM				05:00 PM				04:00 PM			
+0 mins.	4	112	2	118	8	1	2	11	4	211	18	233	4	2	3	9
+15 mins.	2	89	0	91	10	1	3	14	3	203	10	216	3	0	3	6
+30 mins.	2	87	0	89	13	1	3	17	3	191	20	214	2	0	6	8
+45 mins.	7	97	0	104	13	1	5	19	3	210	17	230	0	0	2	2
Total Volume	15	385	2	402	44	4	13	61	13	815	65	893	9	2	14	25
% App. Total	3.7	95.8	0.5		72.1	6.6	21.3		1.5	91.3	7.3		36	8	56	
PHF	.536	.859	.250	.852	.846	1.000	.650	.803	.813	.966	.813	.958	.563	.250	.583	.694

Attachment: Attachment - Signage Assessment for Golden Springs-Golden Prados Memo ("No Right Turn on Red" and "Yield to Pedestrians")

Location: Diamond Bar
 N/S: Golden Springs Drive
 E/W: Golden Prados Drive



Date: 1/30/2025
 Day: Thursday

PEDESTRIANS

	North Leg Golden Springs Drive Pedestrians	East Leg Golden Prados Drive Pedestrians	South Leg Golden Springs Drive Pedestrians	West Leg Golden Prados Drive Pedestrians	
7:00 AM	0	1	0	0	1
7:15 AM	0	1	0	1	2
7:30 AM	0	0	0	0	0
7:45 AM	0	1	0	0	1
8:00 AM	0	1	0	1	2
8:15 AM	0	0	0	0	0
8:30 AM	0	1	0	1	2
8:45 AM	0	0	0	0	0
TOTAL VOLUMES:	0	5	0	3	8

	North Leg Golden Springs Drive Pedestrians	East Leg Golden Prados Drive Pedestrians	South Leg Golden Springs Drive Pedestrians	West Leg Golden Prados Drive Pedestrians	
4:00 PM	2	2	1	2	7
4:15 PM	0	0	0	2	2
4:30 PM	0	2	0	0	2
4:45 PM	0	0	0	0	0
5:00 PM	0	5	0	0	5
5:15 PM	2	0	0	3	5
5:30 PM	1	0	0	0	1
5:45 PM	0	2	0	0	2
TOTAL VOLUMES:	5	11	1	7	24

Attachment: Signage Assessment for Golden Springs-Golden Prados Memo ("No Right Turn on Red" and "Yield to Pedestrians")

Location: Diamond Bar
 N/S: Golden Springs Drive
 E/W: Golden Prados Drive



Date: 1/30/2025
 Day: Thursday

BICYCLES

	Southbound Golden Springs Drive			Westbound Golden Prados Drive			Northbound Golden Springs Drive			Eastbound Golden Prados Drive			
	Left	Thru	Right	Left	Thru	Right	Left	Thru	Right	Left	Thru	Right	
7:00 AM	0	0	0	0	0	0	0	0	0	0	0	0	0
7:15 AM	0	2	0	0	0	0	0	0	0	0	0	0	2
7:30 AM	0	0	0	0	0	0	0	0	0	0	0	0	0
7:45 AM	0	0	0	0	0	0	0	0	0	0	0	0	0
8:00 AM	0	0	0	0	0	0	0	0	0	0	0	0	0
8:15 AM	0	0	0	0	0	0	0	0	0	0	0	0	0
8:30 AM	0	0	0	0	0	0	0	0	0	0	0	0	0
8:45 AM	0	0	0	0	0	0	0	0	0	0	0	0	0
TOTAL VOLUMES:	0	2	0	0	0	0	0	0	0	0	0	0	2

	Southbound Golden Springs Drive			Westbound Golden Prados Drive			Northbound Golden Springs Drive			Eastbound Golden Prados Drive			
	Left	Thru	Right	Left	Thru	Right	Left	Thru	Right	Left	Thru	Right	
4:00 PM	0	0	0	0	0	0	0	0	0	0	0	0	0
4:15 PM	0	0	0	0	0	0	0	0	0	0	0	0	0
4:30 PM	0	1	0	0	0	0	0	1	0	0	0	0	2
4:45 PM	0	0	0	0	0	0	0	0	0	0	0	0	0
5:00 PM	0	0	0	0	0	0	0	0	0	0	0	0	0
5:15 PM	0	0	0	0	0	0	0	3	0	0	0	1	4
5:30 PM	0	0	0	0	0	0	0	0	0	0	0	0	0
5:45 PM	0	0	0	0	0	0	0	0	0	0	0	0	0
TOTAL VOLUMES:	0	1	0	0	0	0	0	4	0	0	0	1	6

Attachment: Attachment - Signage Assessment for Golden Springs-Golden Prados Memo ("No Right Turn on Red" and "Yield to Pedestrians")